



## Charge Control L Datasheet

chargebyte GmbH  
2025-10-17 12:54:31

---

## Contents

4.1	Prevent driving off with connected cable (ASIL B) .....	5
4.2	Prevent disconnect on load (ASIL B) .....	5
4.3	Prevent exceeding thermal operation limits (ASIL B).....	5
4.4	Provide external emergency disconnect signal (ASIL B) .....	6
4.5	Safe State .....	6
5.1	Electrical characteristics .....	6
6.1	30 pin Connector Overview .....	9
6.2	18 pin Connector Overview .....	10
7.1	Vehicle CAN .....	10
7.2	Charging CAN .....	10
7.3	Charging communication.....	10
9.1	Case .....	12
9.2	Header .....	12
9.3	Cable Harness Connectors .....	12
11.1	Automotive Security variant .....	15
12.1	Development Attendant .....	15
12.2	Lab qualification tests .....	15
14.1	Compartment box .....	16
14.2	Delivery package .....	17

# 1 Revisions

Revision	Release Date	Changes
0.1	13.11.2020	Initial release
0.2	17.12.2020	Detail Housing Add charging Sequence
0.3	27.01.2021	Updated Pin Setting for B-Sample
0.4	08.03.2021	Add connectors information
0.5	05.07.2021	Correct PCB pinning of 30pin plug Rework charging sequence Add emergency disconnect Add VCU controlled AC-Charging communication
0.6	18.10.2021	Change colour to CI add 24V Supply add OBC behind VCU concrete temperature measurement
0.7	24.11.2021	Correct cycle time of messages lower estimated weight to measured value
0.8	03.02.2022	Add order code Add LockMotor voltage range Add HVSW_LS current range and HVSW_HS voltage range Add Controller Marking information
0.9	14.03.2022	Add input impedance for FCx and HVSWxFbk Add HVSWSupply electrical characteristics Add fuse remarks change address
0.10	24.05.2022	Added seal plug P/N required for unused pins Add handling of unused pins change default message setting in charging flow
0.11	04.08.2022	Updated operational temperature range Added FC1 usage Added date code to datamatrixcode on label Updated contact information and change of name
0.12	13.10.2022	move charging sequence diagram to user guide
1.0	01.02.2023	add caption
1.1	17.05.2023	add inrush current read pinout list
1.2	08.02.2023	add 003 variant (automotive security) cleanup of Charging CAN availability remove irritating PAR_x from document added pin drawing view point
1.3	29.02.2024	add HMI_supply and sensor supply values
1.4	03.04.2024	correct sizing information
1.5	16.04.2024	add qualification information
1.6	07.06.2024	change CCL Case Picture remove CCL-STD-002
1.7	09.10.2024	add additional qualification tests add Pin positions in Pin layout
1.8	09.12.2024	add altitude add storage time add EOL information add packaging information highlight fuse notes
1.9	11.03.2025	cha description of charging can add additional qualification information
1.10	02.07.2025	add HVSWAllClosedFbk pin rem CONFC2
2.0	17.10.2025	Add new HW Version CBCCL

discontinue I2CCL

## 2 Introduction

The Charge Control L is a stand-alone charge controller that enables DC-charging in commercial vehicles, heavy-duty trucks, and similar applications. The charging communication is compliant to DIN 70121 and ISO 15118. To assure functional safety, this ECU handles safety features up to ISO26262 ASIL B.

Features:

- DC-Charging communication
- AC-Charging communication ( in combination with VCU controlled OBC)
- Inlet controller (PP, CP, PE, lock control, button monitoring)
- Temperature monitoring (AC/DC)
- 2x HV-Interlock
- LED controller (external/ internal control)
- HV-switch controller (welding detection by sequence or feedback contacts)
- OBC connection directly via CAN or behind the VCU
- HomePlug Green PHY 1.1
- CAN-FD and CAN interface

Applied standards:

- Dual mode ISO 15118/DIN 70121 SW Stack (DC)
- IEC61851 and ISO 15118 (AC in combination with OBC)
- ISO 26262
- SAE J1772 (for CBCCL-XXX)
- ECE-R10

Parameter	Value
Power supply	12V / 24V nominal (9-32V)
Processor	2x NXP S32K146
Temperature range	-40°C - 85°C (Industrial)
Storage time	1 Year
Altitude	3000m
Outline dimension	<ul style="list-style-type: none"> <li>• Width: 153.2 mm</li> <li>• Length: 134.6 mm (case) + 18.2mm (header)</li> <li>• Height: 47 mm</li> </ul>
Weight	400g
RoHS	this product is manufactured RoHS compliant.
IP Class	IP6K9K (ISO 20653)

Table 1 CCL Overview

### 3 Applications

Charge Control L is integrated in the low voltage path between inlet and vehicle. The interface to the inlet consists of the standardized CP, PP, PE connections. The interface to the vehicle is a CAN or CAN-FD communication. An optional switch box can be connected via CAN or the switches can be controlled directly. An optional **On-Board Charger** can be connected on the same bus or can be directly controlled by the Vehicle.

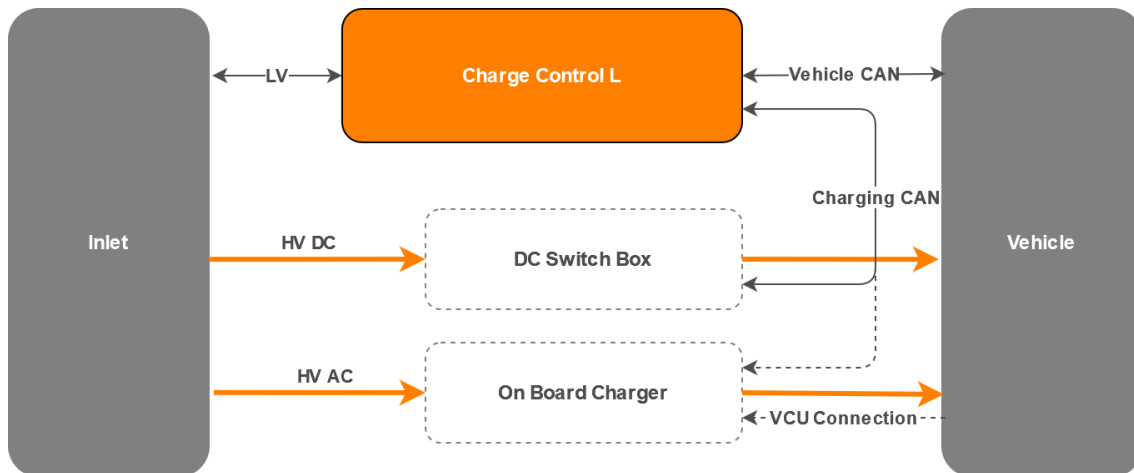

Figure 1 System Overview

### 4 Assumed safety functions

The function regarding functional safety has to be defined at system level, which is in that case the vehicle. Due to the fact, that CCL is only one component in the system, the following safety functions on system level are assumed which have direct impact on CCL.

#### 4.1 Prevent driving off with connected cable (ASIL B)

In case of connected plug, the charging system needs to prevent the drive off. If the vehicle is still connected and drives off the cable can break and injure people by physical damage or electrical shock. The other possibility is, that a SECC is pulled away from its position, so that parts can be thrown away and can hurt people near the car by physical damage or electrical shock. For this function, the CCL provides the plug state, so that the vehicle can suppress the drive off.

#### 4.2 Prevent disconnect on load (ASIL B)

In case of a disconnection during charging, the EVCC provides a lock mechanism, that the plug cannot be removed unintended. If it is removed unintended during charging, there could be a lightning flash which can hurt a human eye. If there is an error in the locking mechanism, the vehicle has the possibility to provide a manual emergency opening of the lock. The second feature for the lock in case of AC charging is to prevent that the connected cable can be stolen. For AC charging the cable belongs to the user and can be removed completely. For DC charging the cable is permanently connected to the SECC.

#### 4.3 Prevent exceeding thermal operation limits (ASIL B)

Due to corrosion or dirt of the contacts in the plug, there could be an increased resistance and so the temperature can be increased in a worst-case scenario it can lead to burn, smoke, or fire. So, the temperature of the plug / inlet needs to be observed during charging. The thermal system is an inert system, so the CCL open the HVSWs within 12 seconds if the temperature limit is exceeded. Prior this emergency opening the CCL provides an optional function to lower the charging current to lower heat build-up. Due to long wiring between inlet and CCL there is a possibility to plug an additional sensor-ECU to the inlet to prevent disruption.

## 4.4 Provide external emergency disconnect signal (ASIL B)

Closed switches in case of an VCU error can be a source of potential harm. So the CCL provides an emergency disconnect signal. If this signal is no longer received as false the CCL opens the HVSWs.

## 4.5 Safe State

As safe state, the CCL provides a disconnection of the HV system.

# 5 Technical Data

## 5.1 Electrical characteristics

### 5.1.1 Absolute maximum ratings

Maximum parameter

Symbol	Description	Min	Max	Unit
<i>CL30</i>	Supply voltage	9	36	V
<i>HVSW_Supply</i>	HV-Switch supply voltage (Additionally Switch dependent)	9	36	V

Table 2 Maximum parameter

### 5.1.2 Recommended operating conditions

Symbol	Description	Min	Typ	Max	Unit
<i>CL30</i>	Supply voltage (12V system)	9	12	16	V
<i>CL30</i>	Supply voltage (24V system)	9	24	32	V
<i>I<sub>CL30</sub></i>	Sleep Current***	-	300	-	μA
<i>I<sub>CL30</sub></i>	Operational Current***	-	0.3	9*	A
<i>I<sub>CL30</sub></i>	Inrush current***	-	0,5	0,7	A
<i>HVSWSupply</i>	Switch Supply voltage (e.q. CL30c)	-	**	32	V
<i>I<sub>HVSWSupply</sub></i>	Switch supply current***	-	**	6	A
<i>T<sub>Case</sub></i>	Top of case temperature (automotive)	-	-	-	°C

Table 3 operation condition

\*Each pin of CL30 can drive 10A. There are two pins mainly for redundancy.

\*\*Typical conditions are dependent from used high voltage switches. (e.q. 12V and 1.5A per Switch)

\*\*\*Values determined with 24V supply voltage.

**fuse design CCL Supply**

For fuse design, the normal operation of CCL does not exceed 0.5A but other loads on CL30 are LockMotor, LEDs, HMI-Supply and SensorSupply. Normally a fuse with more than 10A is not required

### **fuse design HVSWSupply**

On HVSWSupply the only loads are the two external high voltage switches.

Symbol	Description	Min	Typ	Max	Unit
FCx (High)	Function Coding High Level	9	CL30 (12/24)	-	V
FCx (Low)	Function Coding Low Level	-	0	3	V
HVSWxFbk (High)	HV Switch Feedback High Level	9	CL30 (12/24)	-	V
HVSWxFbk (Low)	HV Switch Feedback Low Level	-	0	3	V
Z <sub>FCx/HVSWxFbk</sub>	Input Impedance	75	76	-	kOhm
WU_IN	Wake-up input	2.5	CL30 (12/24)	-	V

Table 4 Input parameter

Symbol	Description	Min	Typ	Max	Unit	Additional Information
HVSWx_HS	HV Switch Highside	-	0.5	1.5 (6A)	A	continuously peak
HVSWx_HS	HV Switch Highside	-	-	HVSWSupply	V	-
HVSWx_LS	HV Switch Lowside	-	0.5	2.0	A	continuously Over current protection at 20A
LockMotor+-	Locking Actuator	-	1.0	9.0	A	Nominal current is 1A but short pulses can be supplied up to 9A.
LockMotor+-	Locking Actuator	-	-	CL30	V	-
HMISupply	HMI supply or Wake up out	-	-	CL30 1,5	V A	switched on while CCL is awake
SensorSupply	external sensor supply or Wake up out	-	-	CL30 1,5	V A	switched on while CCL is awake

Table 5 Output parameter

Symbol	Description	Min	Typ	Max	Unit
TAMB	Operating temperature	-40	-	85	°C
TSTORE	Storage temperature	-40	-	85	°C
RAH	Relative air humidity (non-condensing)	0	-	95	%

Table 6 Environment parameter

## 6 ECU Pinout

Not used pins can be left empty, they will be put on a specific level internally.

Chinch requests to seal unused pins. (See chapter 9.3)

#	Pin	Name	Type	Comment
1	30pin-K1	Charge_CAN_L	Communication	Charging CAN
2	30pin-K2	Charge_CAN_L_OUT	Communication	Charging CAN
3	30pin-K3	ILG1	Output	Interlock Generator
4	30pin-J1	Charge_CAN_H	Communication	Charging CAN
5	30pin-J2	Charge_CAN_H_OUT	Communication	Charging CAN
6	30pin-J3	ILD1	Read back	Interlock Detector
7	30pin-H1	N/A	N/A	N/A
8	30pin-H2	HVSWAllClosedFbk	Input	Combined HV-Switch Feedback to detect all closed (optional)
9	30pin-H3	FC1	Input	Function Coding for cable Tree configuration (UDS channel configuration)
10	30pin-G1	VCU_CAN_L	Communication	Vehicle CAN
11	30pin-G2	VCU_CAN_L_OUT	Communication	Vehicle CAN
12	30pin-G3	ILG2	Output	Interlock Generator
13	30pin-F1	VCU_CAN_H	Communication	Vehicle CAN
14	30pin-F2	VCU_CAN_H_OUT	Communication	Vehicle CAN
15	30pin-F3	ILD2	Read back	Interlock Detector
16	30pin-E1	HVSW1_Fbk	Input	HV-Switch Feedback Contact
17	30pin-E2	HVSW2_Fbk	Input	HV-Switch Feedback Contact
18	30pin-E3	FC0	Input	Function Coding for cable Tree configuration (UDS channel configuration)
19	30pin-D1	SensorSupply	Output	Switchable Supply Voltage for Sensor ECU
20	30pin-D2	HmiSupply	Output	Switchable Supply Voltage for HMI ECU
21	30pin-D3	WU_IN	Input	Wakeup Input (e.q. CL15)
22	30pin-C1	HVSW2_HS	Output	HV-Switch High Side Switch
23	30pin-C2	HVSW1_HS	Output	HV-Switch High Side Switch

24	30pin-C3	HVSW1_LS	Read back	HV-Switch Low Side Switch
25	30pin-B1	CL30-1	Supply	Operational Voltage Supply
26	30pin-B2	CL31-1	Supply	CL31 (GND)
27	30pin-B3	HVSW2_LS	Read back	HV-Switch Low Side Switch
28	30pin-A1	CL30-2	Supply	Operational Voltage Supply
29	30pin-A2	CL31-2	Supply	CL31 (GND)
30	30pin-A3	HVSW_Supply	Supply	Supply Input for HV-Switches (e.q. CL30C)
31	18pin-F1	LockMotor-	Output	Locking Actuator
32	18pin-F2	LED2	Output	LED output (internal control = green)
33	18pin-F3	LED1	Output	LED output (internal control = red)
34	18pin-E1	HmiGnd	Supply	GND pin for HMI ECU
35	18pin-E2	LED3	Output	LED output (internal control = blue)
36	18pin-E3	LED4	Output	LED output
37	18pin-D1	LockMotor+	Output	Locking Actuator
38	18pin-D2	LockFbk+	Output	Locking Feedback
39	18pin-D3	CL31-3	Supply	CL31 (GND)
40	18pin-C1	PE	Shield	Protective Earth directly from the inlet
41	18pin-C2	PP	Output	Proximity Pilot
42	18pin-C3	Btn	Output	Inlet Button
43	18pin-B1	CP	Communication	Control Pilot
44	18pin-B2	TempGnd	Read back	Temperature Measurement Return Path
45	18pin-B3	Temp1	Output	Temperature Measurement Current Source
46	18pin-A1	Temp3	Output	Temperature Measurement Current Source
47	18pin-A2	Temp4	Output	Temperature Measurement Current Source
48	18pin-A3	Temp2	Output	Temperature Measurement Current Source

Table 7 CCL Pinout description

## 6.1 30 pin Connector Overview

View towards ECU header of the CCL (Top-Left corner in view is A1).

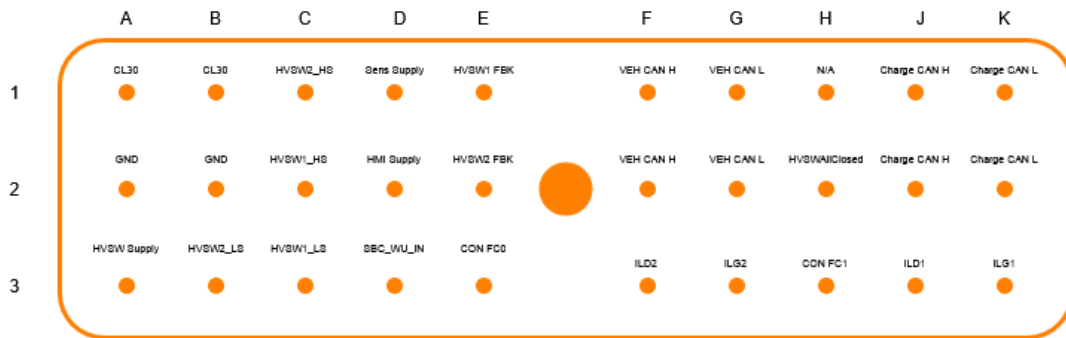

Figure 2 30 pin Connector Overview

## 6.2 18 pin Connector Overview

View towards ECU header of the CCL (Top-Left corner in view is A1).

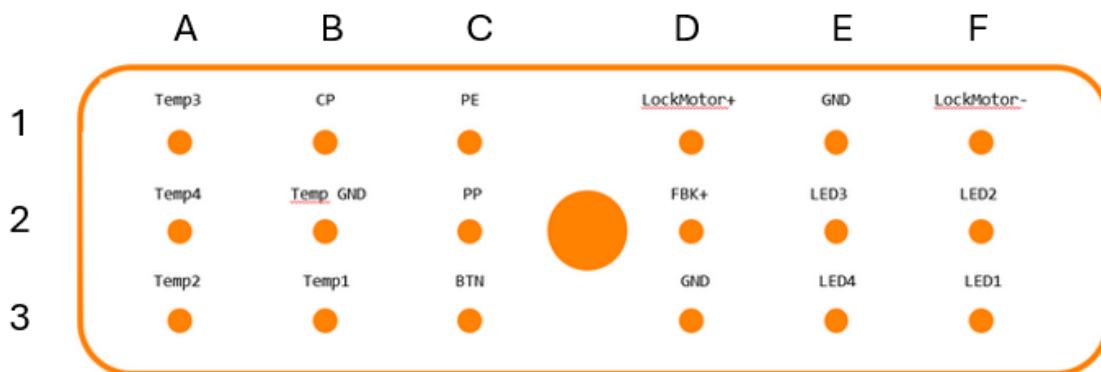

Figure 3 18 pin Connector Overview

## 7 Communication interfaces

### 7.1 Vehicle CAN

The CAN bus for the vehicle interface is configured with a baud rate of 500kbit/s. The interface is defined with a .dbc file which can be requested on request.

### 7.2 Charging CAN

The CAN bus for measurement shunt. The interface is defined with a .dbc file which can be requested if needed. Currently supported:

- IVT-S (Isabellenhütte)
- IVT-3 (Isabellenhütte)

### 7.3 Charging communication

The charging communication is handled via **Control Pilot** as defined in DIN 70121 and ISO 15118. To integrate OBCs and therefore AC functionality the relevant information for IEC61851 are forwarded via CAN.

## 8 Firmware Update

Firmware can be updated via UDS. Documentation as well as a diagnostic tool or UDS service descriptions in .xml can be requested if needed.

## 9 Mechanical Dimensions

[Figure 1](#) shows the housing of Charge Control L. The dimensions are:

- Width: 153.2mm
- Length: 135.8mm (case) + 10.21mm (header) = 146.01mm
- Height: 56.01mm



Figure 4 Charge Control L Housing

[Figure 2](#) shows the 3D model for Charge Control L.

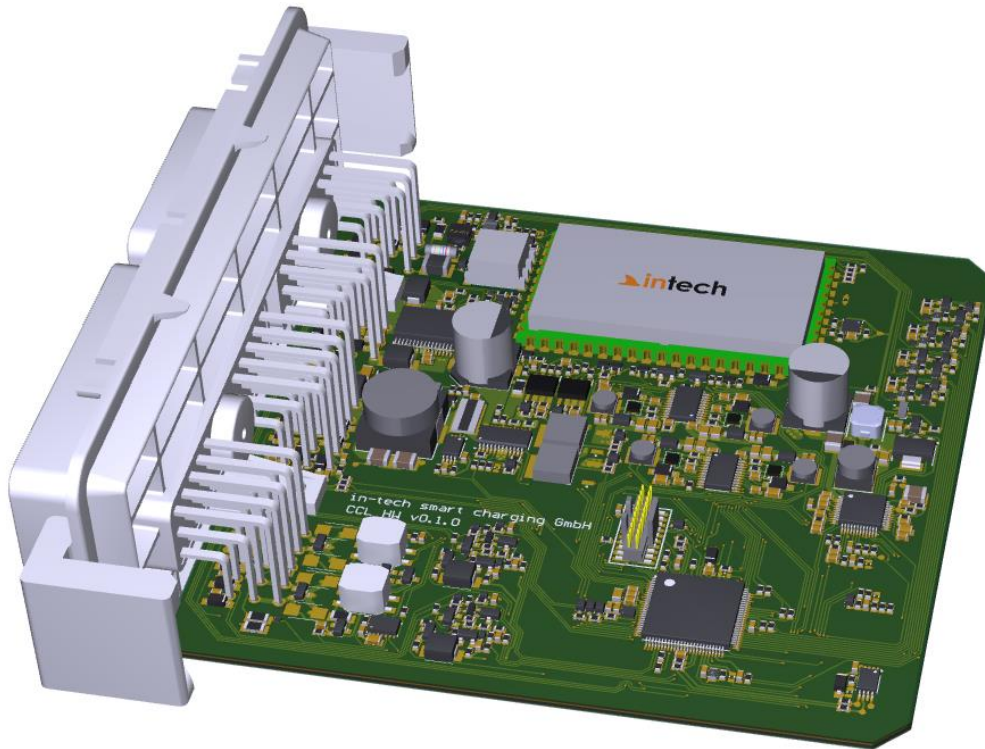

Figure 5 Charge Control L 3D view

## 9.1 Case

Manufacturer: Cinch

P/N: 581 01 30 043

## 9.2 Header

Manufacturer: Cinch

Pins: 48

P/N: 581 01 48 005

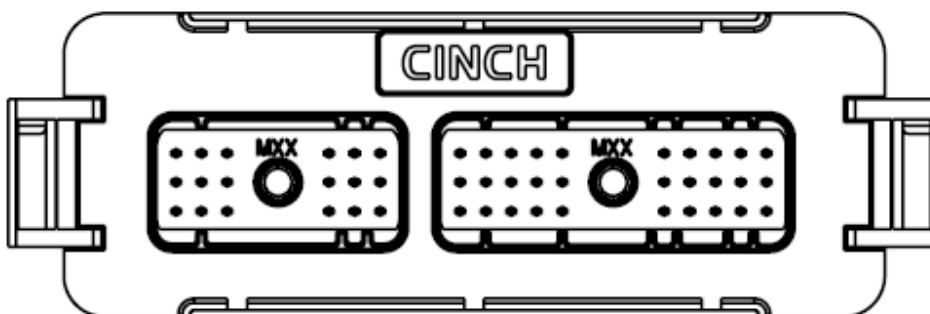

Figure 6 ECU Connector

## 9.3 Cable Harness Connectors

### 9.3.1 Inlet Connector

Manufacturer: Cinch

Pins: 18

P/N: 581 01 18 023



Figure 7 Inlet Connector

Additionally, required Connector PINs with 0.5mm<sup>2</sup>-0.8mm<sup>2</sup> P/N: 425 00 00 872

Additionally, required Connector PINs with 0.8mm<sup>2</sup>-2.0mm<sup>2</sup> P/N: 425 00 00 873

Unused PINs need to be sealed to maintain waterproofing with P/N: 581 00 00 011

### 9.3.2 Vehicle Connector

Manufacturer: Cinch

Pins: 30

P/N: 581 01 30 029



Figure 8 Vehicle Connector

Additionally, required Connector PINs with 0.5mm<sup>2</sup>-0.8mm<sup>2</sup> P/N: 425 00 00 872

Additionally, required Connector PINs with 0.8mm<sup>2</sup>-2.0mm<sup>2</sup> P/N: 425 00 00 873

Unused PINs need to be sealed to maintain waterproofing with P/N: 581 00 00 011

## 10 Controller Marking

Each controller is marked with a label containing the following data:

- Product Order Code
- additional Product information (e.q. "Pre Series") if applicable
- Hardware Version ("HW:")
- Serial Number ("SN:")
- Communication Module MAC address ("XX:XX:XX:XX:XX:XX") (only placeholder in Pre-Series)
- DataMatrix-Code
  - Product Order Code
  - Product Serial Number
  - DateCode of production (Only for CCLs produced after 08-2022)

Example Label:

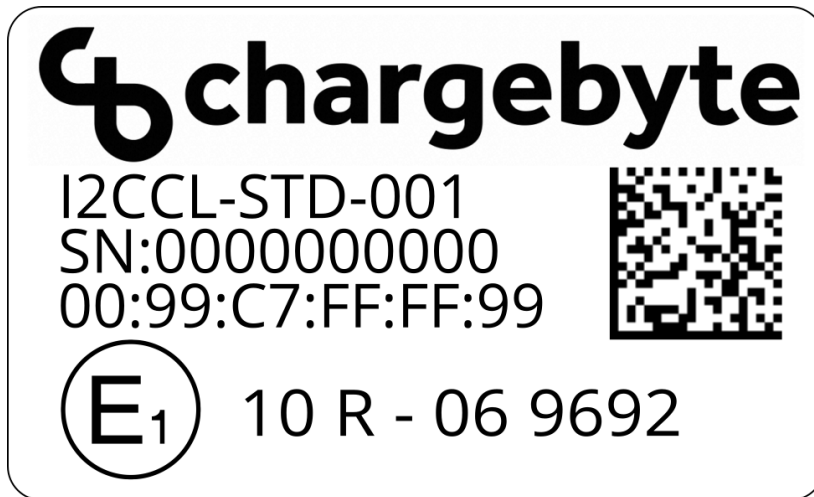

Figure 9 Example Label

## 11 Product Variants / Order Code

Product Family	Variant	Version	Description
I2CCL (discontinued)	-STD-	001	Standard variant, with standard functions
	-STD-	003	Automotive Security variant with standard functions
	-CUS-*		Customer variants
CBCCL	-STD-	001	Standard variant, with standard functions
	-STD-	003	Automotive Security variant with standard functions
	-CUS-*		Customer variants

Table 8 Product variants/ Oder code

\* on Request

## 11.1 Automotive Security variant

The automotive security variant (CBCCL-STD-003) was developed with regards to new regulations for automotive ECUs and their firmware update. It contains all features of the standard variant and additionally:

- Cybersecurity Concept
  - UNECE R 155 (*cybersecurity*)
  - UNECE R 156 (*secure update*)
  - Firmware signing
- Customizable Diagnosis
  - 19 more OEM DIDs
  - 4 Diagnosis Access Levels
  - Customer firmware signing

## 12 Qualification

The CCL underwent several steps of qualification. We decided on a minimum set of accredited laboratory tests for the CCL if further qualification is required we can perform them in collaboration with our customers.

### 12.1 Development Attendant

Lab or developer tests according to regulations without official test report which have been performed and a compliance was achieved.

Electrical Safety	
Norm	Test
ISO 16750-2	Direct Voltage
ISO 16750-2: 2012-11	Over voltage
ISO 16750-2: 2012-11	Slow decrease and increase of supply voltage
ISO 16750-2: 2012-11	Starting profile switch-on hysteresis
ISO 16750-2: 2012-11	Reversed voltage
ISO 16750-2: 2012-11	Short circuits - signal lines
Electromagnetic Compatibility	
EN 61000-6-3	Emission
ISO 7637-2: 2nd edition 2004	Transient Emissions
ISO 7637-2: 2nd edition 2004	Road vehicles, electrical disturbance by conduction and coupling
ISO 7637-3	Road vehicles, electrical disturbance by conduction and coupling
ISO 10605: 2008-07	Electrostatic Discharge (ESD)

### 12.2 Lab qualification tests

Analysis in accredited laboratory with official test report which can be provided on request.

Environmental qualification	Standard	Base Standard
K-01 High- and Low- temperature storage	LV 124: Oct 2009	-
P-03 Parameter test (large)	LV 124: Oct 2009	-
K-02 Step-Temperature-Test	LV 124: Oct 2009	-
M-01 Free-fall Test	LV 124: Oct 2009	-
K-03 Low temperature operation	LV 124: Oct 2009	DIN EN 60068-2-1

K-05 Temperature shock	LV 124: Oct 2009	DIN EN 60068-2-14
K-08 Humid heat, cyclic	LV 124: Oct 2009	
M-05 Mechanical Shock	LV 124: Oct 2009	DIN EN 60069-2-27
M-04 Vibration-test	LV 124: Oct 2009	ISO 16750 - 3
L-03 Lifetime-test with alternating temperature	LV 124: Oct 2009	DIN EN 60068-2-14
Humid. Storage (const. rH and const. T)		IEC 60068-2-67:1995
Change of temperature and humidity	ISO 16750-4 5.6-2:2010	IEC 60068-2-38 Z/AD:2009
Change of temperature and humidity	ISO 16750-4 5.6-3:2010	
Dust Invasion	IP6X	ISO 20653
Electromagnetic Compatibility		
Conducted Immunity, Transients on Power Lines	ISO 7637-2:2011-03	ISO 13766-1:2018-04
E-01 Long Term Overvoltage	LV 124: Oct 2009	
E-04 Jump Start	LV 124: Oct 2009	
E-07 Slow decrease and increase of supply voltage	LV 124: Oct 2009	
E-10 Short interruptions	LV 124: Oct 2009	
E-13 PIN Interruption	LV 124: Oct 2009	
E-15 Reverse polarity	LV 124: Oct 2009	
Component packaging and handling test method	ISO 10605:2014	
Road Clearance EMV		
Radiated emission broadband	ECE R10 rev. 6	CISPR 25
Radiated emission narrowband	ECE R10 rev. 6	CISPR 25
conducted emission of transients (12V and 24V)	ECE R10 rev. 6	ISO 7637-2
Immunity to radiation	ECE R10 rev. 6	ISO 11452-2/4
Immunity to transients on supply lines (12V pulse 4, 24V pulse 1, 2a, 2b, 2c, 3a, 3b)	ECE R10 rev. 6	ISO 7637-2

## 13 End of Line

Each CCL passes an end of line functional test:

- Each circuit is tested at specific sampling points.
- Communication setup and damping

## 14 Packaging specification

### 14.1 Compartment box

Each individual board will be packaged in a separate ESD-compliant bubble wrap bag (21x30cm, unspecified

details). Any adhesive strips remain untouched: The bag will only be folded over, not sealed

A compartment box will accommodate up to 10 boards each, and is assembled as follows:



## 14.2 Delivery package

5 compartment boxes will be packed into an outer carton and sealed with reinforced chargebyte tape. The edges of these outer cartons will be additionally secured with cross-reinforced tape. This way, 50 CCL units can be packed in one outer carton (Article No. 246934004311, BB-Packaging).

If fewer boxes are being packed, the height of the outer carton can be reduced using height creases, making it suitable for quantities of 30-50 CCL units.



## 15 Contact

chargebyte GmbH  
Bitterfelder Straße 1-5  
04129 Leipzig  
Germany

<https://chargebyte.com/>

## 16 Charge Control L Datasheet Releases

[Charge Control L Datasheet-V1.6.docx](#)